

BASEMENT FLOOR
ONE BEHIND ANOTHER (DOUBLE) - 19 NOS.

PROJECT TITLE :
RAMANIYAM "SENATE"
AT ASHOK COLONY, CHENNAI.

DRAWING TITLE:
SITE CUM BASEMENT FLOOR PLAN

NORTH :

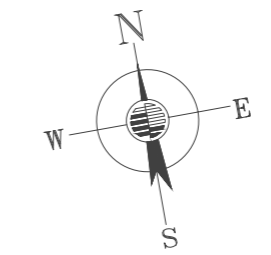

DATE : .25.10.2021

PROMOTERS :
M/S., RAMANIYAM REAL ESTATES (P) LTD.,
 NO : 17/35, 2ND MAIN ROAD,
 GANDHINAGAR, ADYAR,
 CHENNAI - 600 020.
 PH : 0 44 - 43447500 (100 LINES)

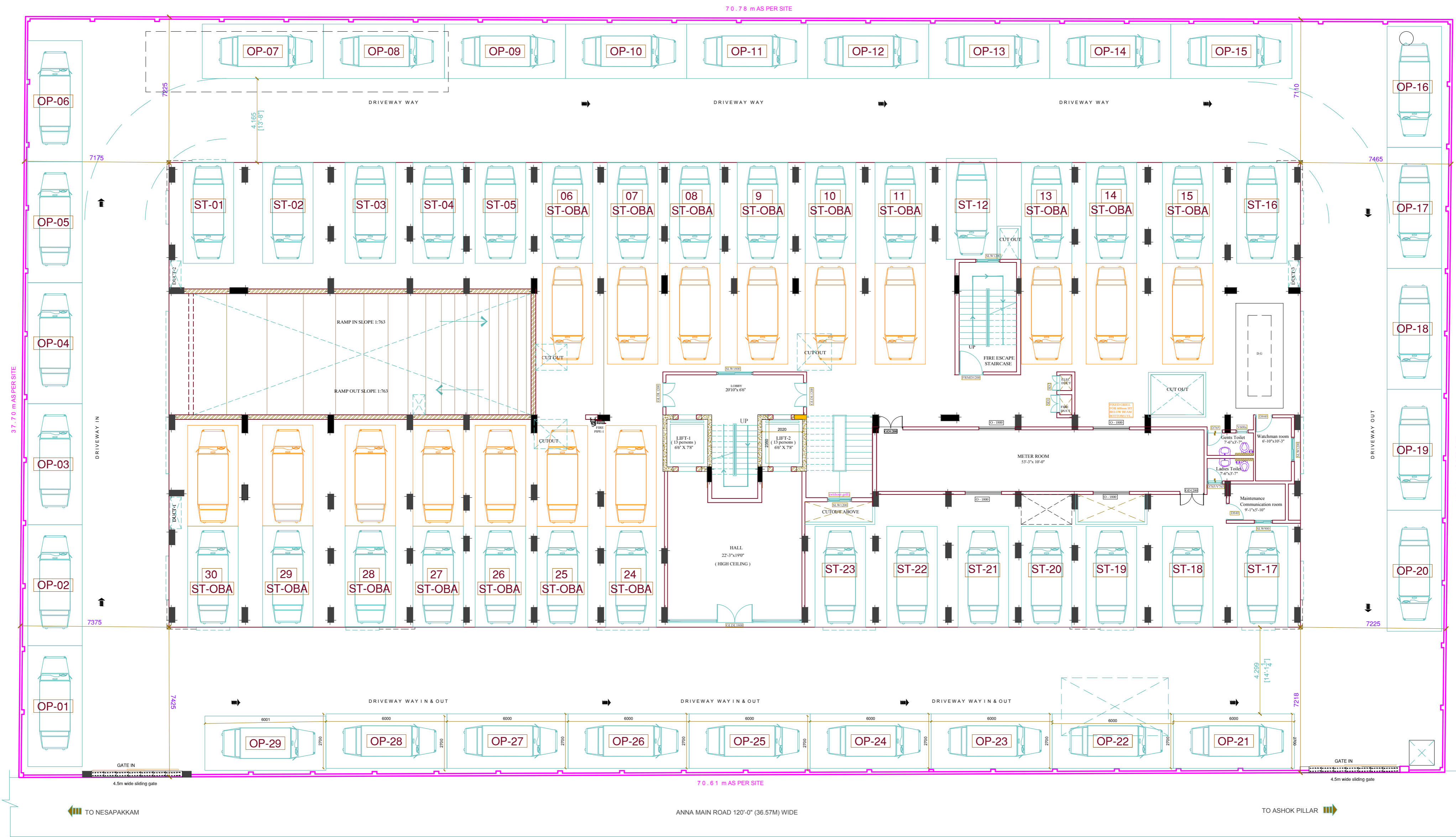

SITE CUM STILT FLOOR:
 ONE BEHIND ANOTHER (DOUBLE) - 16 NOS.
 CARPARKING -COVERED (SINGLE) - 14 NOS.
 CARPARKING -OPEN - 29 NOS.
 TOTAL PARKING IN STILT FLOOR - 59 NOS.

PROJECT TITLE :
 PROPOSED RESIDENTIAL BUILDING
 ASHOK COLONY, CHENNAI.

DRAWING TITLE:
 SITE CUM STILT FLOOR PLAN

NORTH :

DATE : .25.10.2021

PROMOTERS :
 M/S., RAMANIYAM REAL ESTATES (P) LTD.,
 NO : 17/35, 2ND MAIN ROAD,
 GANDHINAGAR, ADYAR,
 CHENNAI - 600 020.
 PH : 0 44 - 43447500 (100 LINES)

56.080
[183'-11 3/4"]



FOR LAND OWNER'S INFORMATION PURPOSES ONLY.

<p>PROJECT TITLE :</p> <p>PROPOSED RESIDENTIAL BUILDING ASHOK COLONY, CHENNAI.</p>	<p>DRAWING TITLE:</p> <p>TYPICAL FLOOR PLAN (1ST TO 9TH FLOOR PLAN)</p>	<p>NORTH :</p>  <p>DATE : 10.03.2021</p>	<p>PROMOTERS :</p> <p>M/S., RAMANIYAM REAL ESTATES (P) LTD., NO : 17/35, 2ND MAIN ROAD, GANDHINAGAR, ADYAR, CHENNAI - 600 020. PH : 0 44 - 43447500 (100 LINES)</p>
---	--	---	--